



Parts List
8" AAT-60 and AAT-90
Auto-Adjust II® Turbo-Meters

Parts List
8" AAT-60 and AAT-90
Auto-Adjust® II Turbo-Meters

Working Pressures:
175, 275, 720 & 1440 psig

8" AAT-60 AND AAT-90 AUTO-ADJUST® II TURBO-METERS

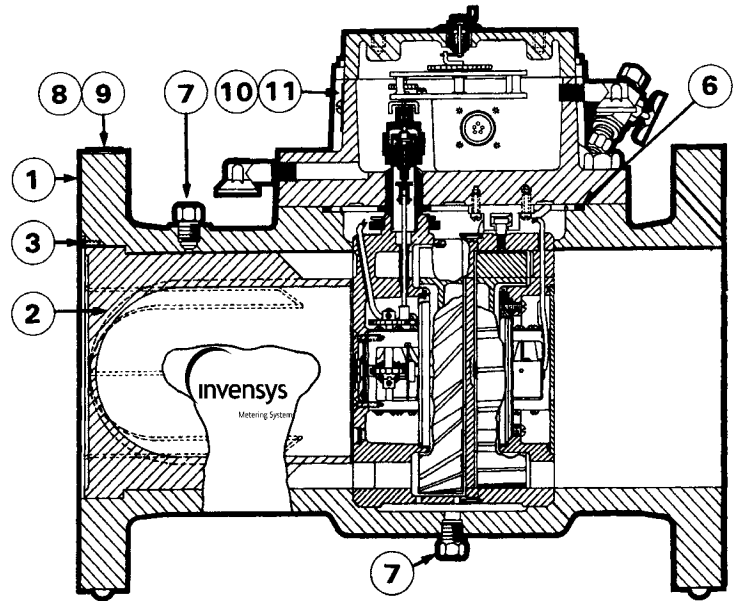
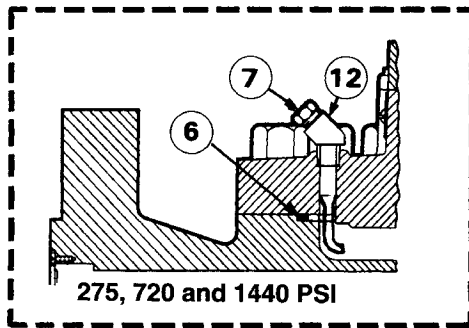

**GENERAL ASSEMBLY
AAT-60 AND AAT-90**

Body Assembly Components

| ILLUSTRATION NUMBER | QUANTITY REQUIRED | PART DESCRIPTION | PART NUMBER |
|---------------------|-------------------|---|-------------------|
| 1 | 1 | Main Body Assembly, Aluminum, 175# W.P. With Badges Less Nose Cone | 006-26-611-20 |
| | | Main Body Assembly, Cast Steel, 275# W.P., ANSI 150 With Badges Less Nose Cone | 006-26-611-21 |
| | | Main Body Assembly, Cast Steel, 720# W.P., ANSI 300 With Badges Less Nose Cone | 006-26-611-60 |
| | | Main Body Assembly, Cast Steel, 1440# W.P., ANSI 600 With Badges Less Nose Cone | 006-26-611-90 |
| | | Main Body Assembly, Cast Steel, 1440# W.P., ANSI 600 With Badges Less Nose Cone With Ring Joint Flanges | 006-26-611-91 |
| 2 | 1 | Nose Cone With Straightening Vanes, All W.P. | 006-26-305-21 |
| 3 | 3 | #8-32 x 3/8" Long Truss Head, Stainless Steel Machine Screw | 950426 |
| 4 | 1 | Manufacturer Nameplate, 175# W.P. | 006-26-073-20-555 |
| 4A | 1 | Manufacturer Nameplate, 275# W.P. | 006-26-073-30-555 |
| 4B | 1 | Manufacturer Nameplate, 720# W.P. | 006-26-073-60-555 |
| 4C | 1 | Manufacturer Nameplate, 1440# W.P. | 006-26-073-90-555 |
| 5 | 4 | Manufacturer Nameplate Drive Screws | 903004 |
| * 6 | 1 | Top Plate to Body "O" Ring, 175# W.P., Buna-N | 934352 |
| * 6A | 1 | Top Plate to Body "O" Ring, 175# W.P., Viton-A (Optional) | 906745 |
| * 6B | 1 | Top Plate to Body "O" Ring, 275#, 720#, 1440# W.P. | 950191 |
| * 6C | 1 | Top Plate to Body "O" Ring, 275#, 720#, 1440# W.P., Viton-A (Optional) | 906746 |
| 7 | 2 | 1/4"-18 Steel Pipe Plug | 906055 |
| 8 | 1 | Inlet Badge (On Inlet Flange of Body) | 015-16-090-02 |
| 9 | 2 | Inlet Badge Drive Screw | 903003 |
| 10 | 1 | Meter Factor Badge (On Top Plate) FT ³ | 006-32-073-10 |
| | | Meter Factor Badge (On Top Plate) M ³ | 006-32-073-11 |
| 11 | 2 | #8-32 x 1/4" Long Round Head Brass Machine Screw | 903055 |
| 12 | 1 | 45° Steel Elbow 1/4" Male to Female for 275#, 720# and 1440# | 950762 |
| 13 | 1 | Internal Mechanism Badge (Not Shown) | 006-36-073-02 |
| 14 | 4 | #0 x 1/8" Long Drive Screw (Not Shown) | 903001 |
| 15 | 1 | C.S.A. Manufacturer Nameplate (Not Shown) | 006-32-074-00 |
| 16 | 4 | Drive Screw for C.S.A. Nameplate (Not Shown) | 903003 |
| * 17 | 1 | Tetraseal, Buna-N | 904076 |

*Recommended Spare Parts

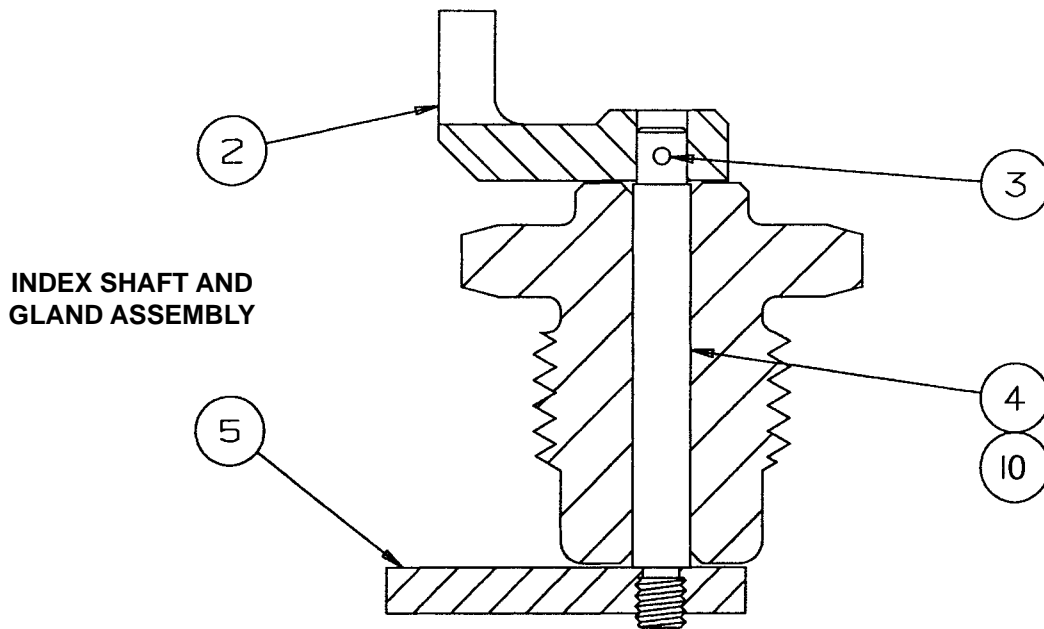
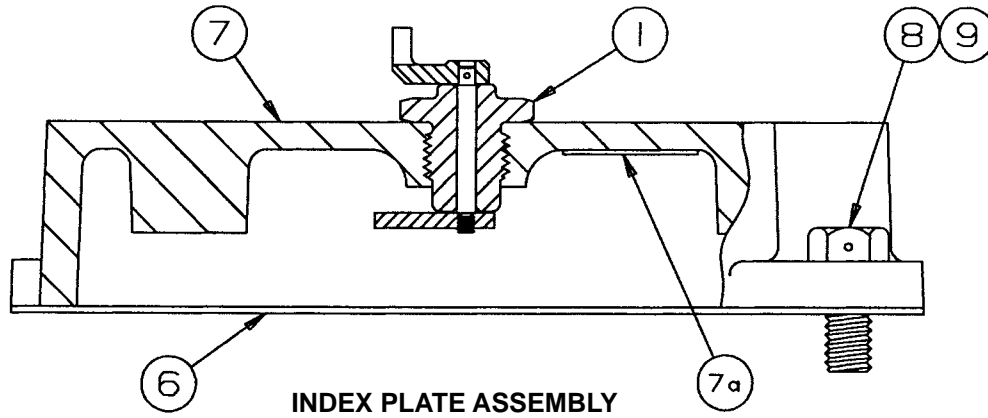

Index Plate Assembly Components

| ILLUSTRATION NUMBER | QUANTITY REQUIRED | PART DESCRIPTION | PART NUMBER |
|---------------------|-------------------|--|---------------|
| 1 | 1 | Index Shaft Gland | 006-24-023-01 |
| 2 | 1 | Top Index Shaft Dog | 006-24-061-04 |
| * 3 | 1 | Shear Pin, Top Index Shaft Dog | 006-24-056-00 |
| 4 | 1 | Index Shaft | 006-24-054-03 |
| 5 | 1 | Bottom Index Shaft Dog | 006-24-071-00 |
| * 6 | 1 | Gasket, Index Plate to Top Plate | 006-24-160-03 |
| 7 | 1 | Index Plate | 006-24-004-21 |
| 7A | 1 | Wiring Label | 006-32-105-00 |
| 8 | 3 | Cap Screw, Index Plate to Top Plate | 910028 |
| 9 | 1 | Seal Cap Screw, Index Plate to Top Plate | 002-65-057-02 |
| 10 | 1 | Index Shaft And Dog Assembly | 006-24-554-02 |

*Recommended Spare Parts

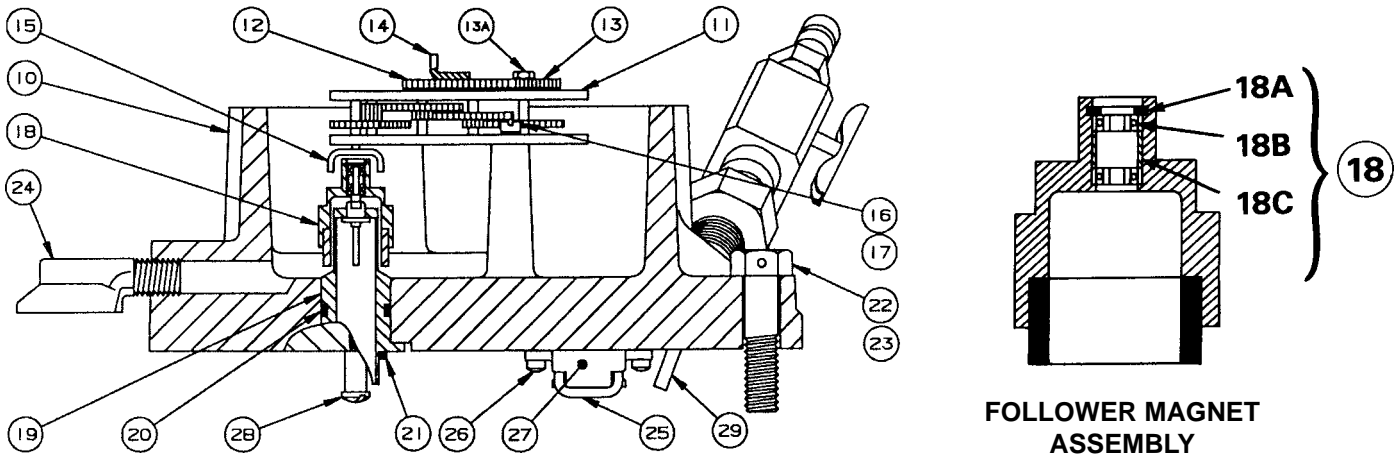

Top Plate Assembly — Mechanical Components

| ILLUSTRATION NUMBER | QUANTITY REQUIRED | PART DESCRIPTION | PART NUMBER |
|---------------------|-------------------|---|---------------|
| 10 | 1 | Top Plate Assembly, Aluminum, 175# W.P. | 006-36-303-20 |
| | | Top Plate Assembly, Cast Steel, 275# W.P. | 006-36-303-31 |
| | | Top Plate Assembly, Cast Steel, 720# W.P. | 006-36-303-91 |
| | | Top Plate Assembly, Cast Steel, 1440# W.P. | 006-36-303-91 |
| 11 | 1 | Intermediate Gear Assembly, 1000 CF/Rev. Output, Less Change Gears | 006-34-212-40 |
| | | Intermediate Gear Assembly, 10 M ³ /Rev. Output, Less Change Gears | 006-36-212-40 |
| 12 | 1 | Large Change Gear (Note: "XX" Refers to Gear Blank (Diameter) Size, "YY" Refers to Number of Gear Teeth. Digits Must Be Substituted for "XX" and "YY" When Ordering). | 006-24-3XX-YY |
| 13 | 1 | Small Change Gear (See Note for Illustration No. 12 Above) | 006-24-3XX-YY |
| 13A | 1 | Small Change Gear Nut, #4-40 Hexagonal Stainless Steel (Not Shown) | 907639 |
| 14 | 1 | Intermediate Gear Output Dog (Top) | 002-66-071-03 |
| 15 | 1 | Intermediate Gear Input Dog (Bottom) | 006-24-061-20 |
| 16 | 3 | Intermediate Gear Retaining Screw | 903371 |
| 17 | 3 | #8 External Lockwasher, Stainless Steel | 950371 |
| * 18 | 1 | Follower Magnet Assembly (Includes Illustration Nos. 18 A-C) | 006-24-313-20 |
| 18A | 1 | Retaining Ring | 904691 |
| * 18B | 2 | Bearing | 905462 |
| 18C | 1 | Spacer | 006-24-106-20 |
| * 19 | 1 | Driver Magnet Well and Post Assembly, 175# & 275# W.P. (Includes Illustration No. 20) | 006-24-244-20 |
| | | Driver Magnet Well and Post Assembly, 720# & 1440# W.P. (Includes Illustration No. 20) | 006-26-244-90 |
| * 20 | 1 | Driver Magnet Well "O" Ring | 950193 |
| | | Driver Magnet Well "O" Ring, Viton (Optional) | 908264 |
| * 21 | 1 | Driver Magnet Well Tetraseal | 904214 |
| * 21A | 1 | Driver Magnet Well Tetraseal, Viton (Optional) | 906736 |
| 22 | 11 | Cap Screw, Top Plate to Body, 175# W.P., 1/2"-13 x 1 3/4" Long Hexagonal Head Steel Grade 5 | 910108 |
| | | Cap Screw, Top Plate to Body, 275# W.P., 1/2"-13 x 1 1/2" Long Hexagonal Head Steel Grade 8 | 950065 |
| | 13 | Cap Screw, Top Plate to Body, 720# & 1440# W.P., 7/8"-9 x 2 3/4" Long Hexagonal Head Steel Grade 8 | 907511 |
| 23 | 1 | Seal Cap Screw, Top Plate to Body, 175# W.P., 1/2"-13 x 1 3/4" Long Hexagonal Head Steel Grade 5 | 006-26-056-00 |
| | | Seal Cap Screw, Top Plate to Body, 275# W.P., 1/2"-13 x 1 1/2" Long Hexagonal Head Steel Grade 8 | 006-26-056-01 |
| | | Seal Cap Screw, Top Plate to Body, 720# & 1440# W.P., 7/8"-9 x 2 3/4" Long Hexagonal Head Steel Grade 8 | 006-26-057-91 |
| 24 | 2 | Vent Cap, 1/4" | 006-24-505-01 |
| 25 | 1 | Extractor Bracket | 006-34-089-01 |
| 26 | 2 | Extractor Bracket Retainer Screw | 903373 |
| 27 | 1 | Spring Clip | 006-41-089-00 |
| 28 | 2 | Adapter Plate Shoulder Screw | 006-32-056-01 |
| 29 | 1 | 1/8"-Aluminum Tubing For Oil System, Unformed | 51911 |

*Recommended Spare Parts

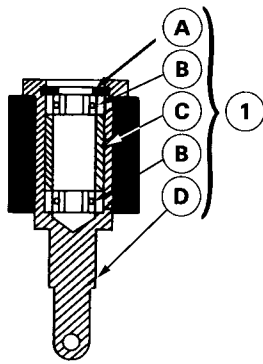

DRIVER MAGNET HOLDER AND BEARING ASSEMBLY

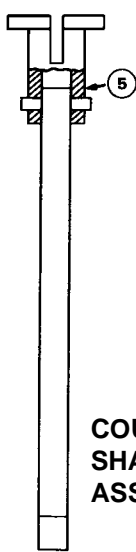

COUPLING SHAFT ASSEMBLY

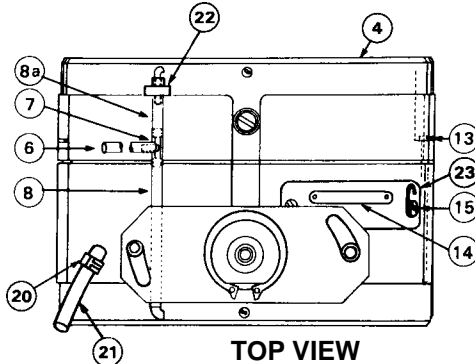

TOP VIEW

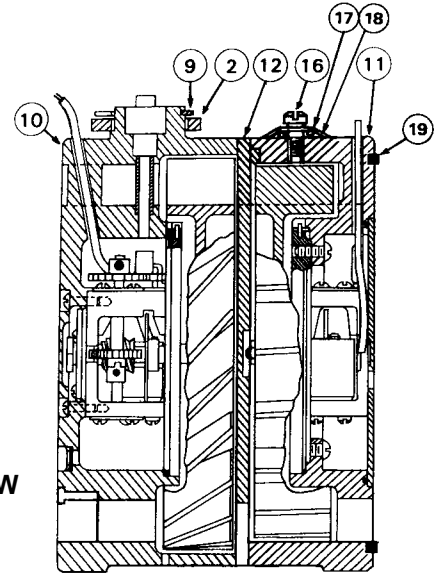

SIDE VIEW

Internal Housing Assembly — Mechanical Components

| ILLUSTRATION NUMBER | QUANTITY REQUIRED | PART DESCRIPTION | PART NUMBER |
|---------------------|-------------------|---|---------------|
| * 1 | 1 | Driver Magnet Holder and Bearing Assembly (Includes Illustration Nos. 1 A-D) | 006-31-334-00 |
| 1A | 1 | Bearing Retaining Ring | 904691 |
| * 1B | 2 | Bearing | 905462 |
| 1C | 1 | Spacer | 006-22-106-03 |
| 1D | 1 | Driver Magnet and Pin Assembly | 006-31-234-02 |
| 2 | 1 | Adapter Plate | 006-32-062-01 |
| 4 | 1 | Internal Housing Assembly, Calibrated with Change Gears, 175# W.P., Cubic Foot (AAT-60) | 006-36-302-01 |
| | | Internal Housing Assembly, Calibrated with Change Gears, 175# W.P., Metric (AAT-60) | 006-36-302-02 |
| | | Internal Housing Assembly, Calibrated with Change Gears, High Pressure, Cubic Foot (AAT-60) | 006-36-302-90 |
| | | Internal Housing Assembly, Calibrated with Change Gears, High Pressure, Metric (AAT-60) | 006-36-302-91 |
| | | Internal Housing Assembly, Calibrated with Change Gears, 175# W.P., Cubic Foot (AAT-90) | 006-46-302-01 |
| | | Internal Housing Assembly, Calibrated with Change Gears, 175# W.P., Metric (AAT-90) | 006-46-302-02 |
| | | Internal Housing Assembly, Calibrated with Change Gears, High Pressure, Cubic Foot (AAT-90) | 006-46-302-90 |
| 5 | 1 | Coupling Shaft Assembly, 175# and 275# W.P. | 006-36-345-20 |
| | | Coupling Shaft Assembly, 720# and 1440# W.P. | 006-36-345-90 |
| 6 | 1 | Oil Tubing, Top Plate to Internal Housing | 99993 |
| 7 | 1 | Tee, 1/8" Polypropylene | 950247 |
| 8 | 1 | Oil Tubing, Tee to Metering Rotor Module | 99993 |
| 8A | 1 | Oil Tubing, Tee to Sensor Rotor Module | 99993 |
| 9 | 1 | Retaining Ring | 904435 |
| ** 10 | 1 | Main (Metering) Rotor Assembly (AAT-60) | 006-36-550-02 |
| | | Main (Metering) Rotor Assembly (AAT-90) | 006-46-550-02 |
| ** 11 | 1 | Sensing Rotor Assembly (AAT-60) | 006-36-550-03 |
| | | Sensing Rotor Assembly (AAT-90) | 006-46-550-03 |
| ** 12 | 1 | Center Plate (AAT-60) | 006-36-109-01 |
| | | Center Plate (AAT-90) | 006-46-109-01 |
| 13 | 2 | Module Connecting Screws NOTE: Maximum Torque = 24 inch-lb. | 950384 |
| 14 | 1 | Serial Number Badge | 006-34-073-01 |
| 15 | 2 | Serial Number Badge Retaining Screw | 950380 |
| 16 | 1 | Shoulder Screw, 1/4" x 1/4" Stainless Steel | 950319 |
| 17 | 1 | "O" Ring, Buna | 934005 |
| | | "O" Ring, Viton | 904839 |
| 18 | 1 | Disc Spring | 950749 |
| 19 | 1 | Tetraseal, Viton | 950708 |
| 20 | 2 | Compression Ring (Pressure Tubing) (AAT-60 Only) | 950772 |
| 21 | | Pressure Tubing (AAT-60 Only) | 800700 |
| 22 | 3 | Compression Ring (Lube Tubing) | 950682 |
| 23 | 1 | Clip for Wires | 950517 |
| 24 | 1 | Retrofit Adapter Kit (Not Shown) | 006-32-190-00 |
| 25 | 1 | Oil Tube Replacement Assembly (Not Shown) (Includes 6, 7, 8, 8A & 22) | 006-36-325-00 |

*Recommended Spare Parts

**Illustration Nos. 10, 11, and 12 affect calibration. These components must be ordered in combination and cannot be supplied as separate items.

MAIN ROTOR ASSEMBLY COMPONENTS

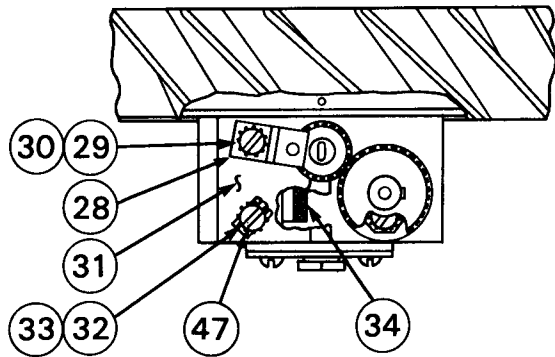

TOP VIEW
BEARING BRACKET

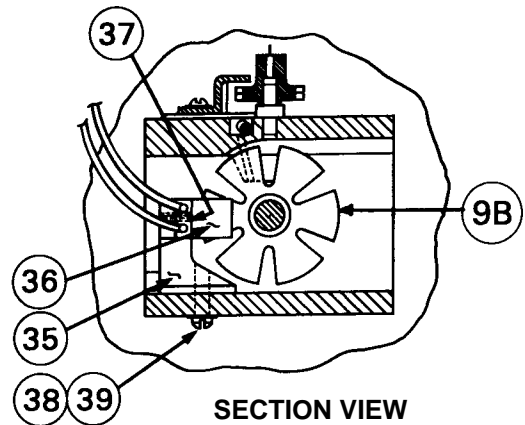

SECTION VIEW
BEARING BRACKET

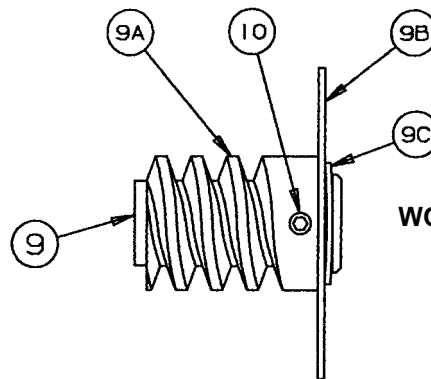

WORM AND CHOPPER
ASSEMBLY

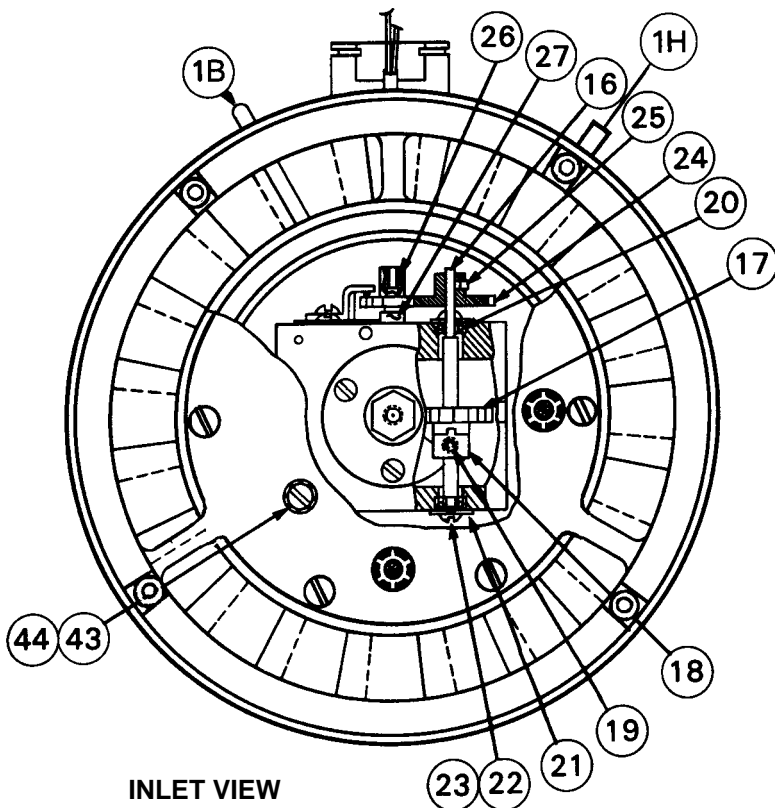

INLET VIEW

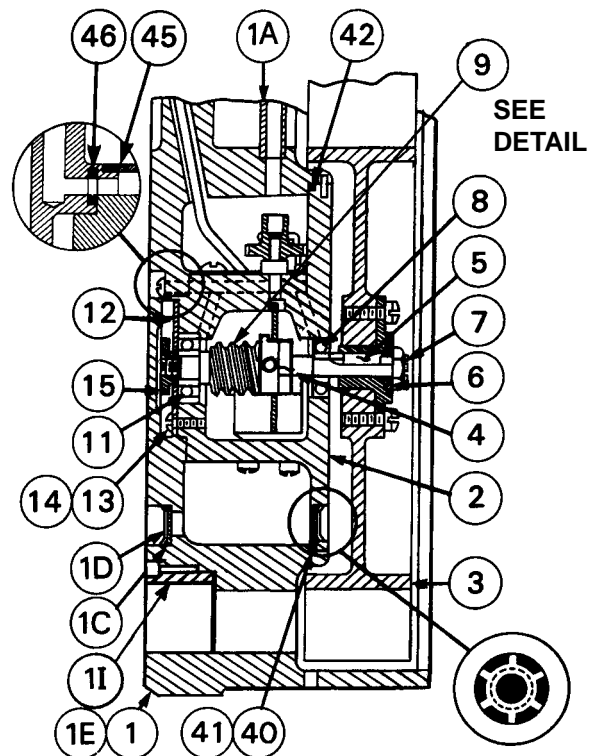

SIDE VIEW SECTION

Main Rotor Assembly Components

| ILLUSTRATION NUMBER | QUANTITY REQUIRED | PART DESCRIPTION | PART NUMBER |
|---------------------|-------------------|---|---------------------|
| ** | 1 | Main (Metering) Rotor Assembly (AAT-60) | 006-36-550-02 |
| | | Main (Metering) Rotor Assembly (AAT-90) | 006-46-550-02 |
| ** 1 | 1 | Carrier Assembly (Includes Illustration Nos. 1 A-I) (AAT-60) | 006-36-519-03 |
| | | Carrier Assembly (Includes Illustration Nos. 1 A-I) (AAT-90) | 006-46-519-03 |
| 1A | 1 | Coupling Shaft Shield Tube | 006-36-082-01 |
| 1B | 1 | Oil Tubing, Aluminum | 006-34-079-01 |
| 1C | 2 | Filter Screen, Stainless Steel | 006-22-083-01 |
| 1D | 2 | Screen Retainer | 904419 |
| ** 1E | 1 | Bearing Bracket Carrier (Includes 1F, G, and I) | 006-36-019-05 |
| 1F | 6 | #6-32 x 1/4" Pan Head Stainless Steel Machine Screw | 950585 |
| 1G | 4 | Module Seal Positioner | 950756 |
| 1H | 1 | Pressure Tap Tube, Aluminum (AAT-60 Only) | 006-34-079-02 |
| 1I | 3 | Vane Insert | 006-36-025-00 |
| 2 | 1 | Bearing Bracket | 006-36-209-00 |
| ** 3 | 1 | Rotor and Insert Assembly (AAT-60) | 006-36-350-02 |
| | | Rotor and Insert Assembly, Machined Main Rotor (AAT-90) | 006-46-350-02 |
| 4 | 1 | Main Rotor Shaft | 006-36-024-02 |
| 5 | 1 | Locking Pin, Rotor to Shaft | 006-24-069-00 |
| 6 | 1 | Spherical Washer | 006-36-077-00 |
| 7 | 1 | Locknut | 906180 |
| * 8 | 1 | Downstream Rotor Shaft Bearing | 950277 |
| 9 | 1 | Worm and Chopper Assembly (Includes 9A, B, C and 10) | 006-36-308-02 |
| 9A | 1 | Worm | 006-34-017-00 |
| 9B | 1 | Chopper Disc (Part of Worm & Chopper Assembly) | Not Sold Separately |
| 9C | 1 | Retaining Ring | 950800 |
| 10 | 2 | Retaining Screw, Worm to Shaft | 950305 |
| * 11 | 1 | Upstream Rotor Shaft Bearing | 906019 |
| 12 | 1 | Upstream Bearing Retainer Plate | 006-36-117-00 |
| 13 | 3 | Retainer Plate Screws | 903013 |
| 14 | 3 | Retainer Plate Screws Lockwasher, #3 Stainless Steel | 950372 |
| 15 | 1 | Retaining Nut, Main Rotor Shaft | 006-36-084-00 |
| 16 | 1 | Wormwheel Shaft | 006-24-046-20 |
| 17 | 1 | Wormwheel (15T) | 006-24-035-00 |
| 18 | 1 | Wormwheel Hub | 006-24-070-02 |
| 19 | 2 | Wormwheel Hub Set Screw | 950375 |
| * 20 | 2 | Wormwheel Shaft Bearing | 908660 |
| 21 | 2 | Bearing Retainer Plate | 006-22-117-01 |
| 22 | 4 | Retainer Plate Screws | 950380 |
| 23 | 4 | #4 External Lockwasher, Stainless Steel | 950078 |
| 24 | 1 | 17T Gear (AAT-60) | 006-26-317-17 |
| | | 23T Gear (AAT-90) | 006-46-317-23 |
| 25 | 1 | Idler Gear Set Screws | 950375 |
| 26 | 1 | 44T Gear (AAT-60) | 006-36-444-44 |
| | | 38T Gear (AAT-90) | 006-46-444-38 |
| 27 | 1 | Drive Gear Post | 006-31-028-00 |
| 28 | 1 | Drive Gear Retainer | 006-24-080-00 |
| 29 | 1 | Drive Gear Retainer Screw | 950380 |
| 30 | 1 | Retainer Screw Lockwasher, #4, Stainless Steel | 950078 |
| 31 | 1 | Oil Reservoir Cover | 006-36-053-00 |
| 32 | 1 | Reservoir Cover Screw | 950380 |
| 33 | 1 | Cover Screw Lockwasher, #4, Stainless Steel | 950078 |
| 34 | 1 | Oil Wick, .09" x .09" | 1191430 |
| 35 | 1 | Slot Sensor Holder | 006-34-078-00 |
| 36 | 1 | Slot Sensor Switch | 006-34-134-00 |
| 37 | 1 | #0-80 x 5/16" Long Flat Head Stainless Steel Machine Screw | 950238 |
| 38 | 2 | #5-40 x 7/16" Long Fillister Head Stainless Steel Machine Screw | 950243 |
| 39 | 2 | #5 Internal Lockwasher, Stainless Steel | 950374 |
| 40 | 1 | Bearing Bracket Filter Screen, Stainless Steel | 006-22-083-01 |
| 41 | 1 | Filter Screen Retainer | 904419 |
| 42 | 1 | Bracket to Carrier Tetraseal | 950424 |
| 43 | 4 | Bracket Retaining Screws | 950373 |
| 44 | 4 | Bracket Retaining Screw External Lockwasher, #6 Stainless Steel | 950144 |
| 45 | 1 | Oil Reservoir Gasket | 006-36-160-07 |
| 46 | 1 | Seal, Oil Passage | 006-36-160-09 |
| 47 | 1 | Wire Clamp | 950407 |

*Recommended Spare Parts

**These items affect calibration and must be ordered in combination with Sensor Assembly, (Center) Plate and Internal Housing.

SENSING ROTOR ASSEMBLY COMPONENTS

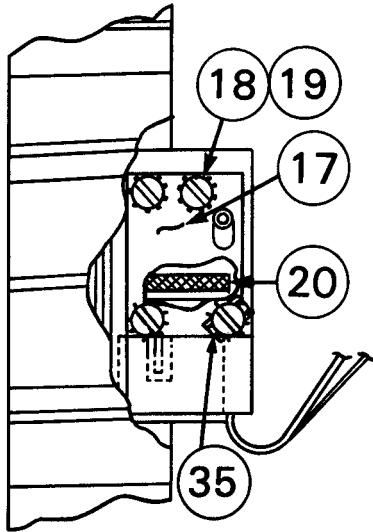

BEARING BRACKET
TOP VIEW

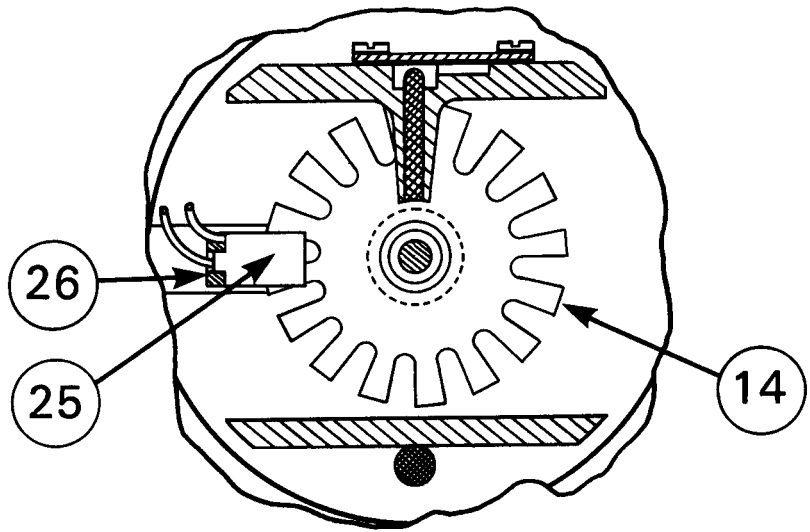

BEARING BRACKET
SECTION VIEW

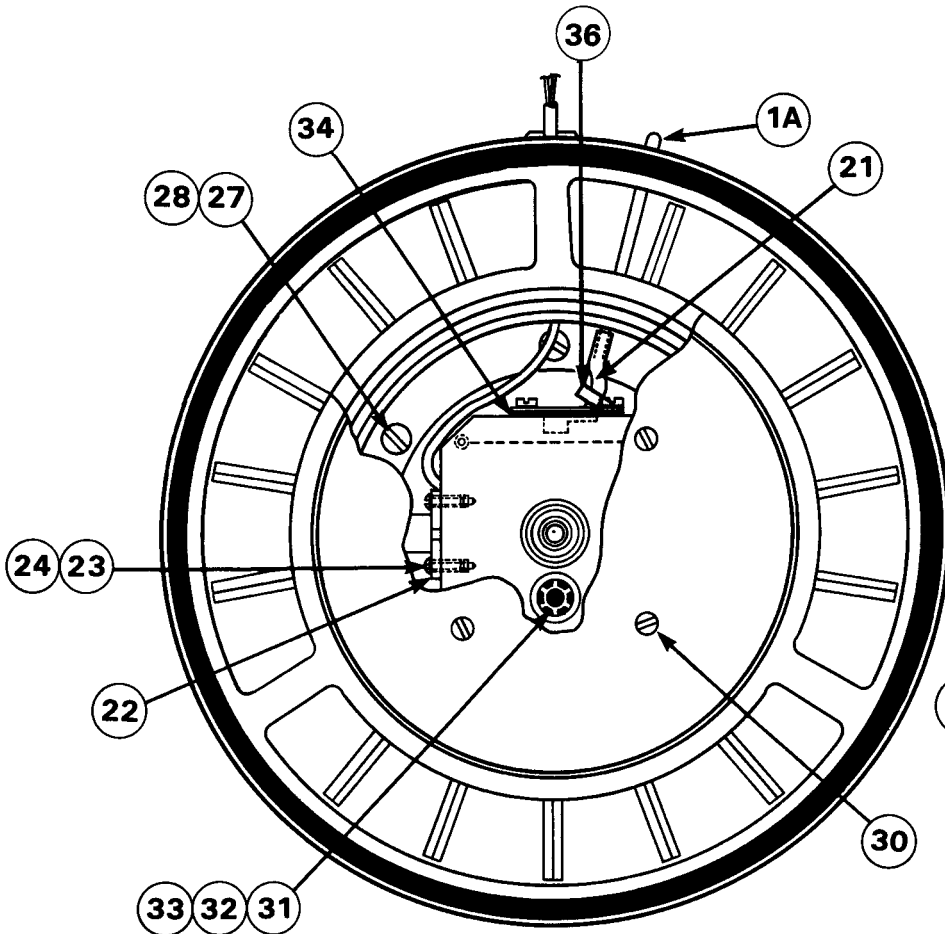

DOWNSTREAM END VIEW

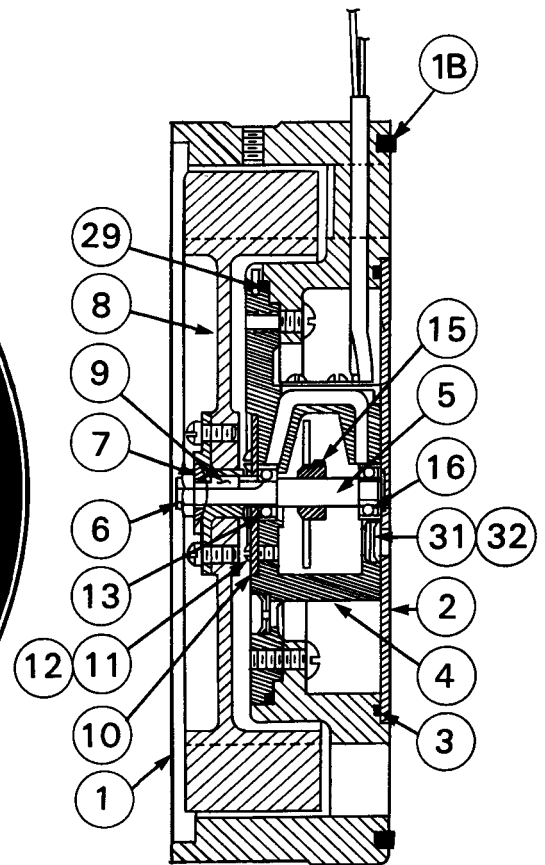

SIDE VIEW
SECTION



Main Rotor Assembly Components

| ILLUSTRATION NUMBER | QUANTITY REQUIRED | PART DESCRIPTION | PART NUMBER |
|---------------------|-------------------|--|---------------|
| ** | 1 | Sensing Rotor Assembly (AAT-60) | 006-36-550-03 |
| | | Sensing Rotor Assembly (AAT-90) | 006-46-550-03 |
| ** 1 | 1 | Carrier Assembly (Includes Illustration Nos. 1A & B) | 006-36-519-02 |
| 1A | 1 | Oil Tube, Aluminum | 006-36-079-01 |
| 1B | 1 | Tetraseal, Viton (Held in w/Bostik Adhesive 4585, P/N 905120) | 950708 |
| 2 | 1 | Housing Plate | 006-36-010-00 |
| 3 | 1 | Tetraseal | 908553 |
| 4 | 1 | Bearing Bracket | 006-36-221-00 |
| 5 | 1 | Rotor Shaft, Stainless Steel | 006-36-024-01 |
| 6 | 1 | Locknut | 906180 |
| 7 | 1 | Spherical Washer | 006-36-077-00 |
| ** 8 | 1 | Rotor and Insert Assembly (AAT-60) | 006-36-350-01 |
| | | Rotor and Insert Assembly (AAT-90) | 006-46-350-01 |
| 9 | 1 | Rotor Locking Pin | 006-24-069-00 |
| 10 | 1 | Upstream Bearing Retainer Plate | 006-36-117-01 |
| 11 | 3 | #3-48 x 5/16" Long Round Head Stainless Steel Machine Screw | 903013 |
| 12 | 3 | #3 Internal Lockwasher, Stainless Steel | 950372 |
| * 13 | 1 | Upstream Rotor Shaft Bearing | 950277 |
| 14 | 1 | Chopper Disc Assembly (Includes 15) | 006-36-308-01 |
| 15 | 1 | #4-40 x 1/8" Long Hexagonal Stainless Steel Set Screw, Nylon Locking | 950305 |
| * 16 | 1 | Downstream Rotor Shaft Bearing | 950277 |
| 17 | 1 | Oil Reservoir Cover Assembly | 006-36-253-00 |
| 18 | 4 | Cover Retaining Screws | 950380 |
| 19 | 4 | #4 External Lockwasher | 950078 |
| 20 | | Oil Wick, .09" x .09" | 1191430 |
| 21 | | Tubing for Oiling System | 99993 |
| 22 | 1 | Slot Sensor Holder | 006-36-078-00 |
| 23 | 2 | Holder Retaining Screw | 903013 |
| 24 | 2 | #3 Internal Lockwasher, Stainless Steel | 950372 |
| 25 | 1 | Slot Sensor Switch Assembly | 950563 |
| 26 | 1 | Switch Retainer Screw | 950238 |
| 27 | 6 | Carrier to Bracket Retaining Screws | 908722 |
| 28 | 6 | #8 External Lockwasher, Stainless Steel | 950371 |
| 29 | 1 | Tetraseal, Carrier to Bracket | 950278 |
| 30 | 4 | Bracket Retaining Screws | 903110 |
| 31 | 2 | Filter Screen, Stainless Steel | 006-22-083-01 |
| 32 | 2 | Screen Retainer, Truarc, Stainless Steel | 904419 |
| 33 | 1 | Tetraseal | 950320 |
| 34 | 1 | Gasket, Oil Reservoir | 006-36-160-08 |
| 35 | 1 | Wire Clamp | 950407 |
| 36 | 1 | Compression Ring | 950682 |
| | | Oil, 4 Ounce Bottle, RFEM | 006-22-405-01 |
| | | Oil, 1 Gallon Can | 006-22-405-02 |
| | | Lubrication Hand Gun | 006-24-400-00 |
| | | Blank Top Plate, 175# W.P. | 006-26-003-25 |
| | | Blank Top Plate, 275# W.P. | 006-26-003-26 |
| | | Blank Top Plate, 720#, 1440# W.P. | 006-26-003-92 |

*Recommended Spare Parts

**These items affect calibration and must be ordered in combination with Main Rotor Assembly and Decoupling (Center) Plate.

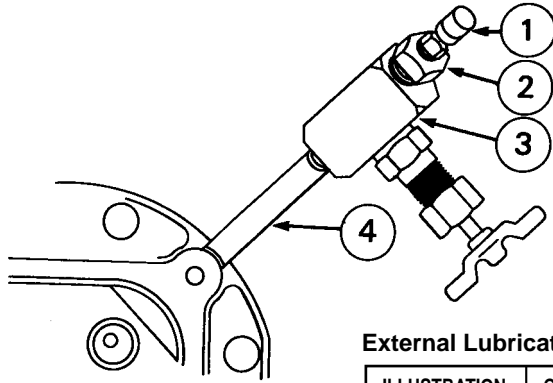

TOP PLATE

External Lubrication System Fittings

| ILLUSTRATION NUMBER | QUANTITY REQUIRED | PART DESCRIPTION | PART NUMBER |
|---------------------|-------------------|-----------------------------------|-------------|
| 1 | 1 | Lubrication Gun Fitting | 907887 |
| 2 | 1 | Hex Bushing 1/4" to 1/8" Steel | 950759 |
| 3 | 1 | Valve, 1/4" Carbon Steel (HP) | 950710 |
| 3A | 1 | Valve, 1/4" Brass (LP) | 950428 |
| 4 | 1 | Pipe Nipple, 1/4" x 3" Steel (HP) | 950760 |
| 4A | 1 | Nipple, 1/4" x 3" Brass (LP) | 904765 |

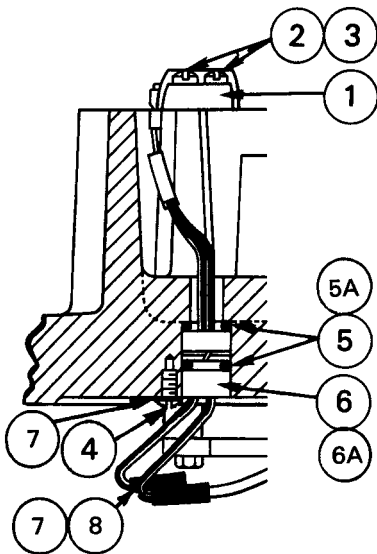

Electrical System Fittings

| ILLUSTRATION NUMBER | QUANTITY REQUIRED | PART DESCRIPTION | PART NUMBER |
|---------------------|-------------------|---|---------------|
| 1 | 1 | Terminal Block | 950364 |
| 2 | 4 | #8-32 x 3/8" Long Stainless Steel Machine Screw | 903371 |
| 3 | 4 | External Lockwasher, #8, Stainless Steel | 950371 |
| 4 | 1 | #8-32 x 3/8" Long Stainless Steel Machine Screw | 903371 |
| 5 | 2 | "O" Ring | 946861 |
| 5A | 2 | "O" Ring, Viton | 902418 |
| 6 | 1 | Feed-Through Assembly | 950588 |
| 6A | 1 | Feed-Through Assembly, Viton | 006-32-317-00 |
| 7 | 1 | Washer, Stainless Steel | 950448 |
| 8 | AR | Solder | 750155 |
| 9 | AR | Shrink Tube | 800633 |

CONDUIT TYPE

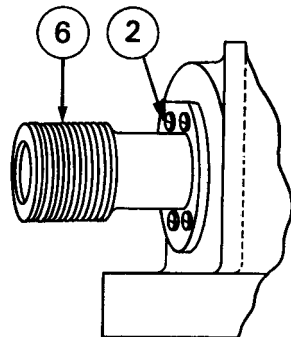

PLUG-IN TYPE

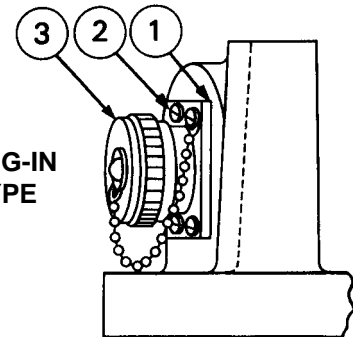

External Wiring Fittings

| ILLUSTRATION NUMBER | QUANTITY REQUIRED | PART DESCRIPTION | PART NUMBER |
|---------------------|-------------------|---|---------------|
| 1 | 1 | Gasket | 905321 |
| 2 | 4 | #8-32 x 1/4" Long Round Head Stainless Steel Machine Screw | 903055 |
| 3 | 1 | Cap and Chain Assembly for Plug-In Connector | 006-32-131-00 |
| 4 | 1 | Plug-In Connector, Female End (Not Shown) | 950388 |
| 5 | 1 | Plug-In Connector, Male End With Wiring to Terminal Block (Not Shown) | 006-34-250-00 |
| 6 | 1 | Conduit Adapter Assembly, 1/2"-14 NPT With Wiring to Terminal Block | 006-34-330-00 |

AAT-60 AND AAT-90 TURBO-METER WIRING SYSTEM COMPONENTS

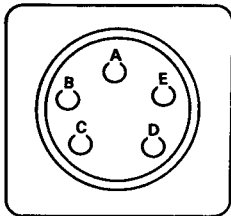
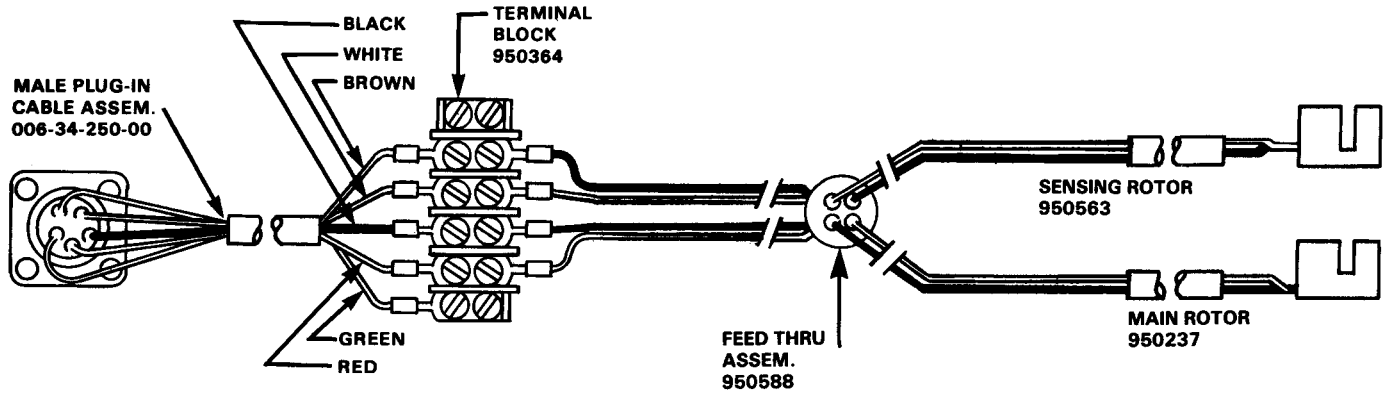

PLUG-IN CONNECTOR MALE END

TERMINAL BLOCK DETAIL

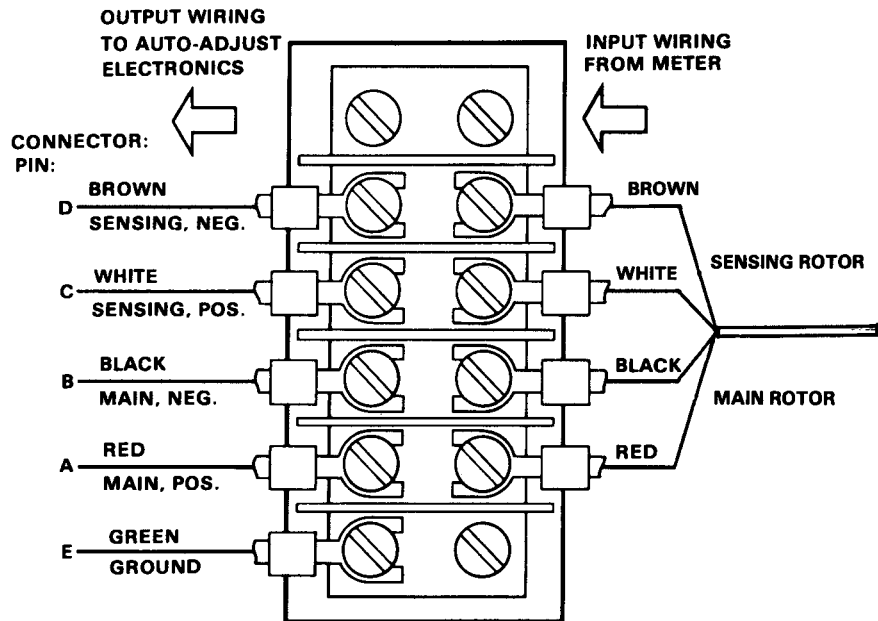

TERMINAL BLOCK WIRING DETAIL FOR PLUG-IN OR CONDUIT TYPE CONNECTORS



805 Liberty Boulevard
DuBois, PA 15801
814-375-8875
Fax 814-375-8460

Authorized Distributor

Limited Warranty

Seller warrants the Goods to be free from defects in materials manufactured by Seller and in Seller's workmanship for a period of one (1) year after tender of delivery (the "Warranty Period"). THIS LIMITED WARRANTY (a) IS IN LIEU OF, AND SELLER DISCLAIMS AND EXCLUDES ALL OTHER WARRANTIES, STATUTORY, EXPRESS OR IMPLIED, INCLUDING, WITH LIMITATION, ANY WARRANTY OF MERCHANTABILITY OR FITNESS FOR A PARTICULAR PURPOSE, OR OF CONFORMITY TO MODELS OR SAMPLES; (b) does not apply to any Goods which have been (i) repaired, altered or improperly installed; (ii) subjected to improper use or storage, (iii) used or incorporated with other materials or equipment, after buyer or anyone using the Goods has, or reasonably should have, knowledge of any defect or nonconformance of the Goods; or (iv) manufactured, fabricated or assembled by anyone other than Seller, (c) shall not be effective unless buyer notifies Seller in writing of any purported defect or nonconformance with (thirty days) after Buyer discovers or should have reasonably discovered such purported defect or nonconformance; and (d) shall only extend to Buyer and not to any subsequent buyers or users of the Goods. Buyer shall provide Seller access to the Goods as to which Buyer claims a purported defect or nonconformance, upon request by Seller, buyer shall, at its own risk and expense, promptly return the Goods in question to Seller's Plant.